

2014 *FIRST*[®] LEGO[®] League (FLL[®]) Challenge

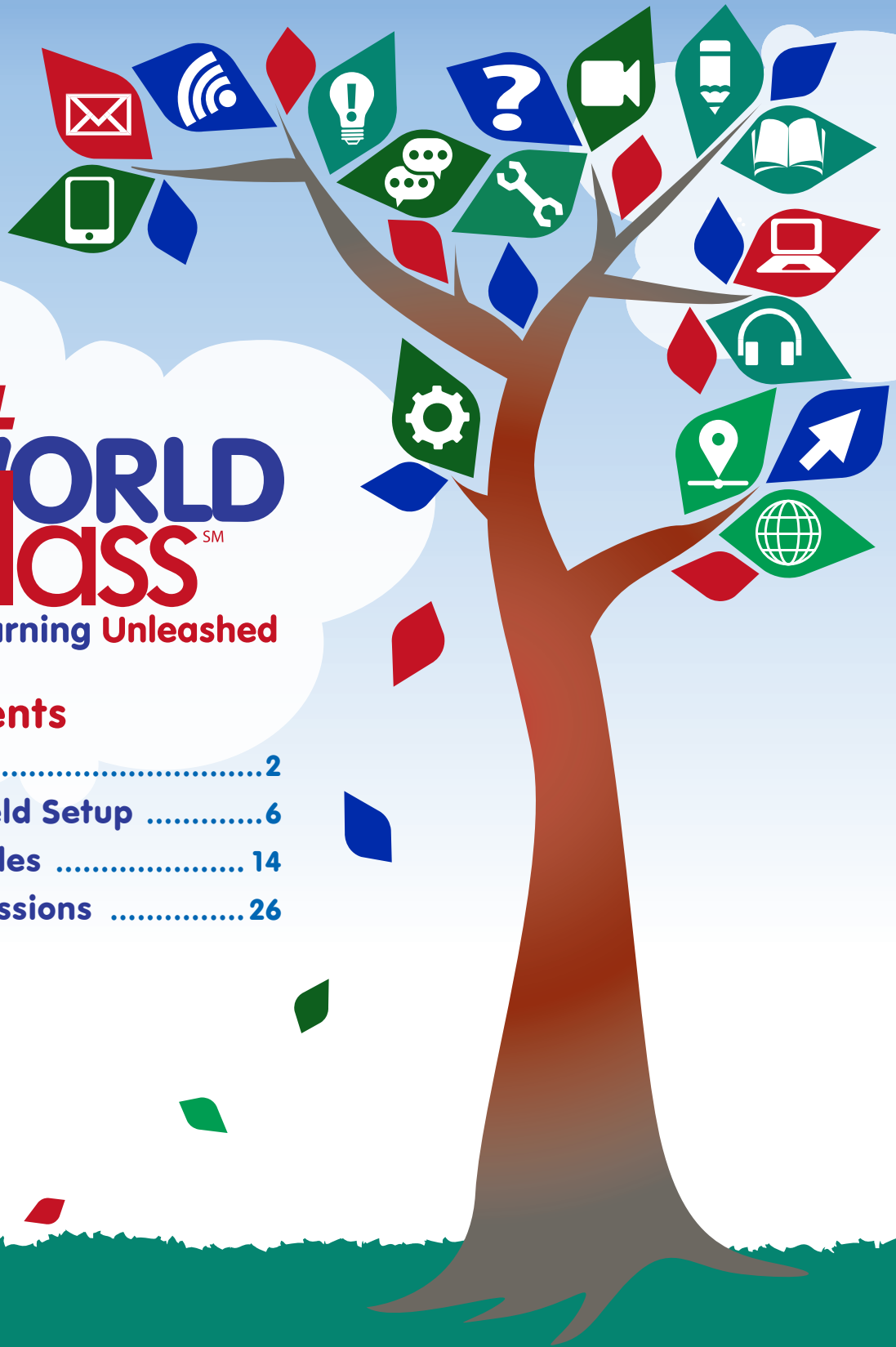

Table of Contents

Project	2
Robot Game – Field Setup	6
Robot Game – Rules	14
Robot Game – Missions	26



The Project



In the FLL WORLD CLASSSM Project, your team will:

- Choose a topic that you are passionate about or always wanted to learn.
- Create an innovative solution that improves the learning experience.
- Share your solution with others.

Think About It

You have probably learned so many things in your life that it is hard to count them. You started learning as soon as you were born. You learned to walk, tie your shoes, and how to read this Challenge. You might have learned to dance, paint, or play an instrument. You might even have learned how to kick a soccer ball at the perfect angle to score a goal.

To have fun in many core subjects — like history, science, art, and math — you need to develop specific skills. In fact, skills are your tools to learn at any age. They might include:

- Critical thinking
- Teamwork
- Creativity
- Problem solving
- Communication
- Information literacy (knowing how to find and use the information you need)
- Understanding technology

There is so much to learn, but people do not all learn the same way. Just like there is more than one way to build your robot, there is more than one way to learn most things. We call these different ways of learning “learning styles.” Most people learn through some combination of watching, listening, reading, writing, moving, and even playing. Do you have a favorite way to learn new knowledge or skills?

No matter what learning style you use most, there are many surprising tricks that might help a person learn. For example:

- Some video games help you understand how the three-dimensional world fits together. This skill is called “spatial reasoning.” It could help you engineer and innovate.
- Singing the rules of a new game might help you remember them more easily than reading them.
- Building with LEGO bricks could help you learn math and engineering concepts. (You probably knew that already – you’re in FLL!)

Some learning tools or techniques might make learning more exciting, while others help you remember the information for a longer time. **Your Project mission this season is to find a better or more innovative way to help someone learn.**

Looking for a fun way to start thinking about the FLL WORLD CLASSSM Project?
Check out the [Communicate It! activity](#) on www.firstlegoleague.org.



Identify your FLL WORLD CLASS Question

First, choose a topic and find out how people learn about it today. Researchers, teachers, psychologists, and others are always making new discoveries about how we learn. Like a professional researcher, you will write a “research question” and find your own answer. We will call this your FLL WORLD CLASSSM Question

To get started, think about all the topics you have learned about in the last day, week, or month. Make a list. You might have learned something in one of these places, but include topics you learned in other places too:

- Classroom
- Library
- Playground or park
- Internet
- Home
- Activity center like a band room, art studio, or karate school
- Museum
- Natural area like a forest, prairie, or desert

Look at each team member’s list. What did you learn and how did you learn it? Did you have any difficulties learning any particular topic? Did you use any tools or objects to help you learn each one?

AS A TEAM – Select one topic you are passionate about and use it to write down your FLL WORLD CLASS Question. You could choose a topic from your own list or something else that interests your team. For the FLL WORLD CLASS Project, a topic may be very broad (ex: science) or very specific (ex: the different parts of a cell).

Write your FLL WORLD CLASS Question using this format: “How could we improve the way that someone learns [your team’s topic]?”

Then research all the ways people learn about this topic today. You might use books, interviews, the internet, radio, TV or lots of other resources to answer questions like:

- How do people usually find out about your topic for the first time?
- What tools or technology do students usually use to learn about it?
- Why is this topic important and who is it important to?
- Does the location or method matter when learning about this topic?

This might be a great time to interview a professional. The professional could be someone who teaches the topic you selected or works with it every day. How did they learn about your topic? Why are they passionate about it? Did they like the topic when they first learned about it? What are the drawbacks to the way people learn about this topic today?

AS A TEAM – After your brainstorming and research, you should have a good idea of the current answers to your team’s FLL WORLD CLASS Question. Discuss whether you need any further information before you begin designing your own solution.

Create an Innovative Solution

Now your challenge is to design an innovative solution to your FLL WORLD CLASS Question – **a solution that adds value to society by improving something that already exists, using something that exists in a new way, or inventing something totally new.** Your solution might improve the learning experience for someone on your team or for someone else.

Think about:

- How can your solution make learning easier or more fun?
- Can it help you learn something yourself? Or help you teach what you know to someone else?
- What could be done better? What could be done in a new way?
- What new tools or processes would help someone remember the information for a longer time?

Optional: You can find a chart on www.firstlegoleague.org to help you organize your list.



AS A TEAM – Think about it! Brainstorm! Use your problem-solving skills to think about all the possible solutions. Discuss all your ideas. One team member’s “silly idea” just might inspire the perfect innovative solution.

A great solution might take all the imagination and ingenuity your team can muster. Or, it might seem so obvious that you wonder why we don’t learn that way today.

Using your research, think about how someone could make your solution a reality.

- Is your idea different in some way from all the other solutions to learn about this topic?
- What would your solution cost?
- Do you need any special technology to make your solution?
- Can anyone use your solution or only some people?

Remember, your solution could improve something that already exists, use something that exists in a new way, or invent something totally new.

Share with Others

Once you have a design or plan for your solution, share it!

AS A TEAM – Think about who your solution might help. How can you let them know? Can you present your research and solution to people who learn or teach? Can you share with a professional or someone who helped you learn about your topic? Or other students in your school? Can you think of any other groups of people who might be interested in your idea?

Consider sharing with someone who could provide feedback about your idea. Getting input and improving are part of the design process for any engineer. Don’t be afraid to revise your idea if you receive some helpful feedback.

When you present, use the talents of your team members. Find a creative way to explain your **FLL WORLD CLASS Question** and solution. Could you perform a skit? Create a website? Make a comic book? Rap? Write a poem, song, or story? Your sharing can be simple or elaborate, serious or designed to make people laugh while they learn.

And remember, the most important thing is to have fun!

Present Your Solution at a Tournament

Finally, prepare a presentation to share your work with the judges at a tournament. Your presentation can include posters, slideshows, models, multimedia clips, your research materials, and more. Be creative, but also make sure you cover all the essential information.

To be eligible for Project Awards and advancement, your team must:

1. Identify your team’s **FLL WORLD CLASS Question**.
2. Explain your team’s innovative solution.
3. Describe how your team shared your findings with others.
4. Meet the presentation requirements:
 - Give your presentation live; you may use media equipment (if available) but only to enhance the live presentation.
 - Include all team members; each team member must participate in the Project judging session in some way.
 - Set up and complete your presentation in 5 minutes or less with no adult help.

You can learn more about how your team’s presentation will be judged by reviewing the Rubrics located at <http://www.firstlegoleague.org/event/judging>.

More Project Resources (Optional)

- Check the Project Updates often: <http://www.firstlegoleague.org/challenge/projectupdates>. Here FLL staff will clarify common Project questions. Postings contain official information that will be in effect at tournaments.
- View the 2014 Challenge page: <http://www.firstlegoleague.org/challenge/2014fllworldclass>. Download the Topic Guide for a glossary of education words, a list of websites and books to start your research, and tips on how to approach professionals.
- The *FIRST*® LEGO® League Coaches' Handbook contains more information about the Challenge, tournaments, and judging: <http://www.firstlegoleague.org/challenge/teamresources>.

Still have questions about the FLL Project? Send an email to fllprojects@usfirst.org for Project support.



Learning is part of life. You do it every day.

**Now YOU have the power to say
how you think people should learn something new.**

Whether your solution helps you, someone you know, or someone you have never met,
helping someone learn can have an impact for the rest of that person's life.

Help FLL make learning a true WORLD CLASS experience!





Robot Game Field Setup

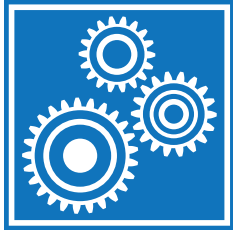

The field is where the Robot Game takes place.

- It consists of a field mat, on a table with border walls, with mission models arranged on top.
- The field mat and the LEGO® pieces (elements) for building the mission models are part of your Field Setup Kit.
- The instructions for building the mission models are [here](#).
- The instructions for how to build the table and how to arrange everything on it are below...

Table Instructions

The Robot Game takes place on a specially designed table, so you'll need to build one to practice on if you don't already have access to one. With safety, weight, height, and cost in mind, a simple design is offered here, but as long as your surface is smooth, and your border walls are sized and located properly, how you build the understructure is up to you. The construction is simple, but does require some wood-working skills.

At a tournament, two tables are placed back to back, but you only operate on one table, so you only need to build one table to practice on. We'll call your practice table a "half-table."

Most challenges have a "shared" mission model, which rests partly on your table, and partly on the other team's table. So in addition to building your table, you'll need to build a small portion of a second table, so both halves of the shared model are supported. We'll call this added section the "dummy wall."

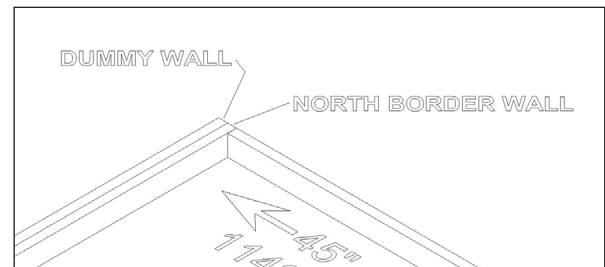

Materials

Material	Quantity
Field Setup Kit (mission model LEGO elements, mat, CD, Dual Lock™)	1
sanded plywood (or other very smooth board) 96" X 48" X at least 3/8" (2438mm X 1219mm X 10mm)	1
two-by-three, 8' (2438mm) [actual cross-section = 1-1/2" X 2-1/2" (38mm X 64mm)]	6
flat black paint	1 pt. (1/2 L)
coarse drywall screws, 2-1/2" (64mm)	1/2 lb. (1/4 kg)
saw horses, about 24" (610mm) high and 36" (914mm) wide	2

Parts

Part	Make From	Dimensions	Paint	Quantity
table surface (A)	plywood	96" X 48" (2438mm X 1219mm)	no	1
long border wall (B)	two-by-three	96" (2438mm)	yes	3
short border wall (C)	two-by-three	45" (1143mm)	yes	2
stiffener (D)	two-by-three	48" (1219mm)	no	4
saw horse	purchase	H \approx 24" W \approx 36" (610mm) (914mm)	no	2

Assembly

Step 1 - Determine which face of the plywood (A) is least smooth, and consider that the bottom face. On the bottom face, clamp then screw on the stiffeners (D) about every 18" or 457mm. Be sure screw heads and splinters don't protrude.

Step 2 - On the top face of the plywood, locate, clamp, and screw on the border walls (B,C) around the top perimeter.

- The wall-to-wall dimensions must measure $93\pm 1/8"$ by $45\pm 1/8"$ ($2362\pm 3\text{mm}$ by $1143\pm 3\text{mm}$).
- The height of B and C must measure between $2\text{-}1/2"$ (64mm) and $3\text{-}1/2"$ (90mm).
- All border walls must be the same height as each other on all tables at a tournament. Border heights at a tournament may be different than those on your practice table.

Step 3 - Place this table top on short saw horses (or milk crates, or anything else short and solid).

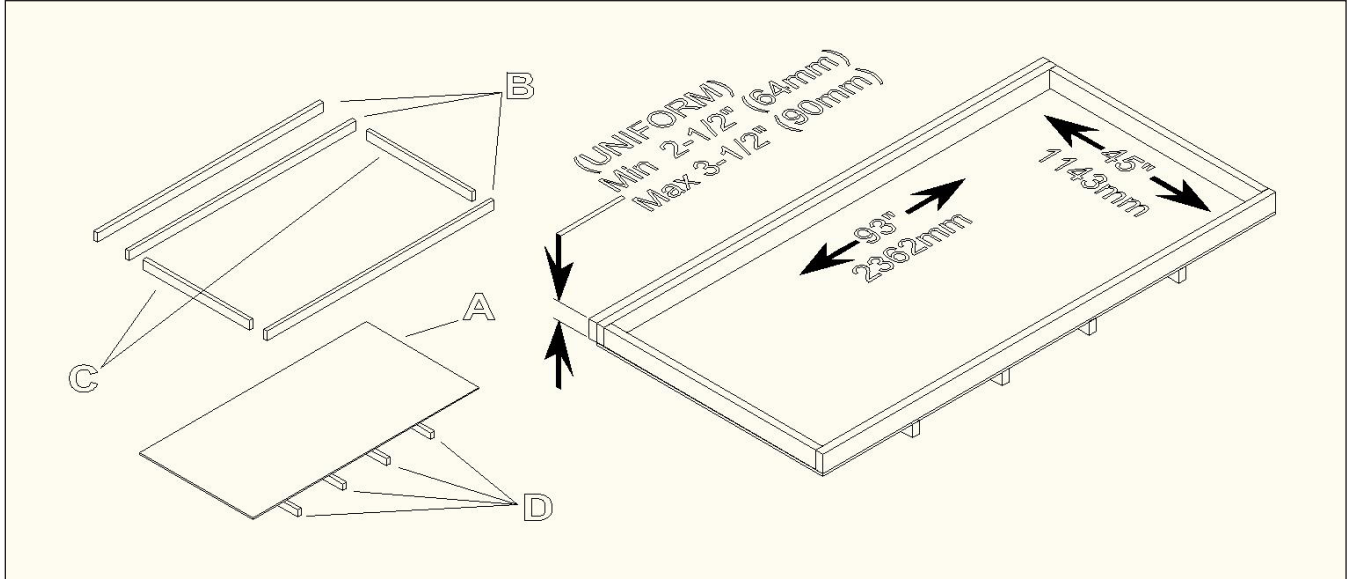

Field Mat Placement

Step 1 - Vacuum the table top. Even the tiniest particle under the mat can give the robot trouble. After vacuuming, run your hand over the surface and sand or file down any protruding imperfections you find. Then vacuum again.

Step 2 - On the vacuumed surface (never unroll the mat in an area where it could pick up particles), unroll the mat so the image is up and its north edge is near the north/double border wall (note the location of the double wall in each table sketch below). BE VERY CAREFUL TO NOT LET THE MAT KINK (BEND IN TWO DIRECTIONS AT ONCE).

Step 3 - The mat is smaller than the playing surface by design. Slide and align it so that there is no gap between the south edge of the mat and the south border wall. Center the mat in the east-west direction (look for equal gaps at left and right).

Step 4 - With help from others, pull the mat at opposite ends and massage out any waviness away from the center and re-check the requirement of Step 3. It is expected that some waviness will persist, but that should relax over time. Some teams use a hair dryer to speed the relaxation of the waviness.

Step 5 - OPTIONAL – To hold the mat in place, you may use a thin strip of black tape at the east and west ends. Where the tape sticks to the mat, it may cover the mat's black border only. Where the tape sticks to the table, it may stick to the horizontal surface only, and not the walls.

Step 6 - For a competition setup, dummy walls are not needed. Secure two tables north-to-north. The total span of border between two tables must measure between 3" (76mm) and 4" (100mm).



PRACTICE ("HALF TABLE")

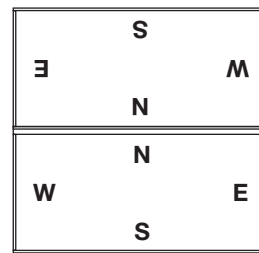

TOURNAMENT ("FULL TABLE")

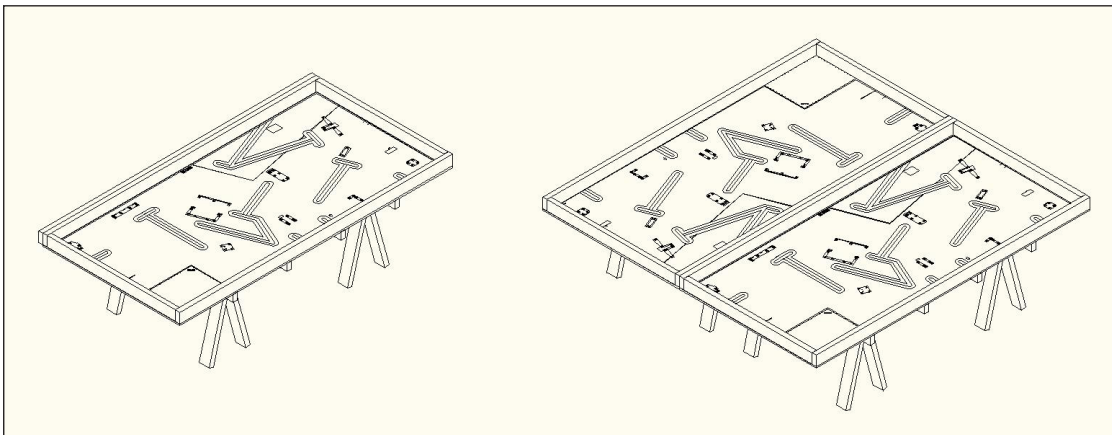

Mission Model Construction

BUILD THE MISSION MODELS - Use the LEGO elements from your Field Setup Kit, and instructions from this page. It will take a single person four to five hours to do this, so it's best done in a work party. For any team members with little or no experience building with LEGO elements, mission model construction is a great way to learn. This step is also a nice time for new team members to get acquainted with each other.

Mission Model Arrangement and Setup

DUAL LOCK™ - Some models are secured to the mat, others are not. Where a model needs to be secured, the connection is made using the re-usable fastening material from 3M called Dual Lock, which comes in the flat clear bag with the LEGO elements in your Field Setup Kit. Dual Lock is designed to stick or “lock” to itself when two faces of it are pressed together, but you can unlock it too, for ease of transport and storage. The application process for the Dual Lock is only needed once. Later, the models can simply be locked onto the mat or unlocked. To apply Dual Lock:

Step 1 - Stick one square, adhesive side down, on each box you see on the mat with an “X” in it.

Step 2 - Press a second square on top of each of those, “Locking” them on, adhesive side up.

TIP - Instead of using your finger, use a bit of the wax paper the squares came on.

Step 3 - Lower the model onto the squares.

CAUTION - Pay attention... Some models look symmetrical, but do indicate a directional model feature somewhere.

- Be sure to place each square precisely on its box, and each model precisely over its marks.

- When pressing a model down, press down on its lowest solid structure instead of crushing the whole model. Pull on that same structure if later you need to separate the model from the mat.

TIP - For large and/or flexible models, apply only one or two sets at a time. There's no need to do it all at once.

MODELS - (Any details not shown or mentioned are left to chance.)

Scale - Secure as shown.

Search Engine - Secure and as shown, with push-bar all the way west, and loops in exact colors as shown.

Soccer (Football) - Secure net and barrier as shown.

Box - Place loose as shown. The slab (idea) inside has its white edge facing west and yellow bulb facing south.

Community Tree - Secure as shown, and press any loop into it so the sides rise.

Senses - Secure as shown, with slider all the way west, and any loop captured in the grabber.

Cloud - Secure as shown, with SD card down/west.

Loops - Place one loose as shown on its mark at south center. Be sure the tubes for all are uniform and parallel.

Robotic Arm - Secure as shown, with slider north, and claw closed/capturing any loop.

Engagement - Secure as shown, with yellow section north, a red arm up, and the white dial pointer down/south.

Changing Conditions - Secure as shown, fully settled with south barrier against its stopper.

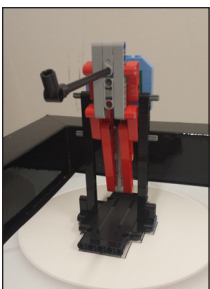

SCALE

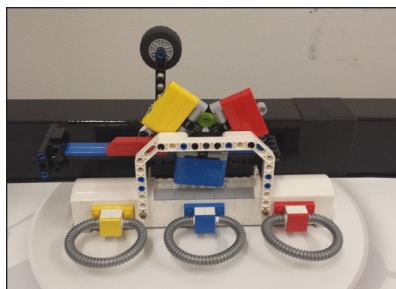

SEARCH ENGINE

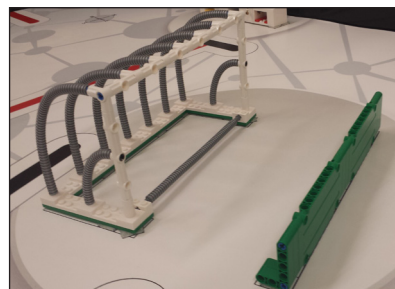

SOCCKER

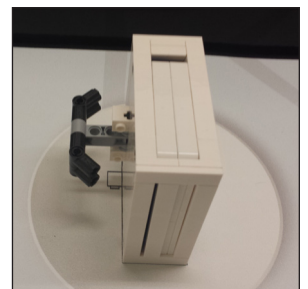

BOX

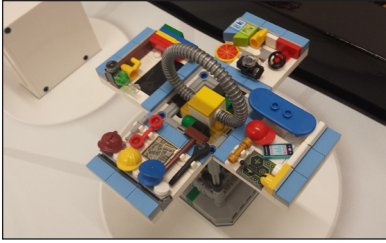

COMMUNITY TREE

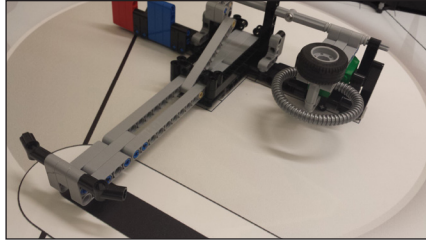

SENSES

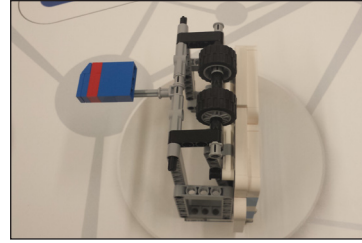

CLOUD

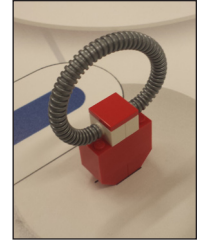

LOOPS

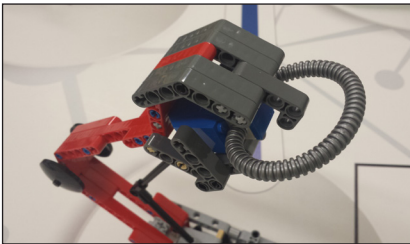

ROBOTIC ARM

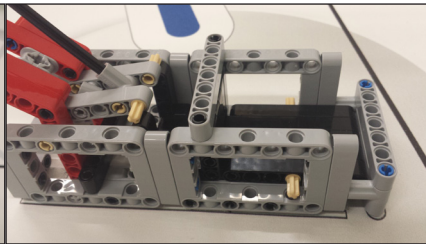

ENGAGEMENT

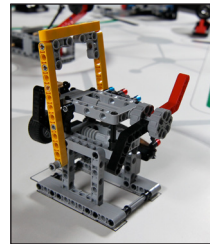

CHANGING CONDITIONS

Reverse Engineering - You have several sets of six loose elements. Two of those sets are for the robot field (the rest are related to the FLL Project). Regarding the two robot field sets: ONE set is placed loose in Base. With the OTHER set (all six pieces)... Build your own random or artistic (it doesn't matter) little model, place it in the basket on its mark in the northeast corner of the field, and close the basket's covers as much as possible.

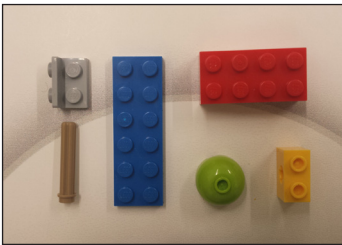

FROM THIS...

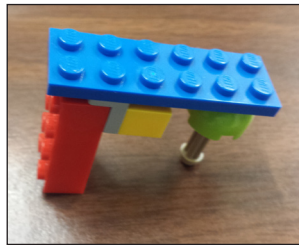

BUILD SOMETHING LIKE THIS (JUST ONE)
THESE ARE JUST EXAMPLES

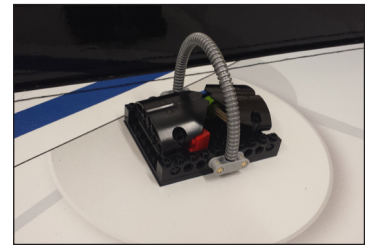
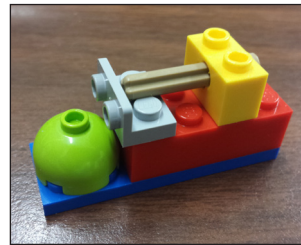

AND PLACE IT LIKE THIS

Door - This model is secured to the west border wall, north of Base. There are no "X" squares to guide you, but there are marks on the mat, and these pictures show the needed detail... Place the pairs on the door as shown, then press to the wall between the lines. Setup is with the door closed all the way, and the handle lifted.

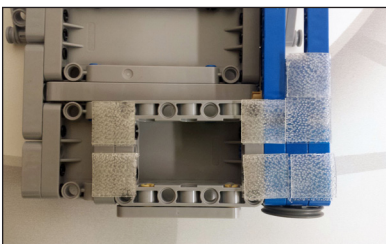

DOOR - PLACE DUAL LOCK PAIRS



PRESS NORTH OF THESE LINES



PRESS SOUTH OF THIS LINE

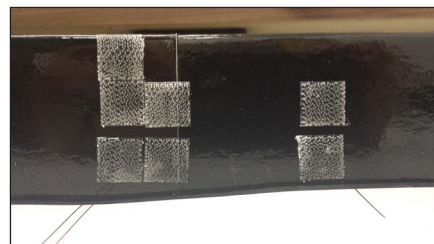

DOOR - WALL PATTERN ("ish")



SETUP



Screen And Camera - There are three up-front things to say about this system of models:

- 1) Both teams (you and your opponent) need to operate this system for it to work.
- 2) This system's full setup takes added care and patience (but really, for anyone doing robotics, it's no big deal).
- 3) You only really need to set up part of the system in order to practice.

Here's how the operation works: Your robot pulls a "camera" model, and by string, it activates a remote "screen" model IF the other team ALSO participates. When both teams participate, both teams score. Since you can't guarantee your opponents will participate and succeed, all you can do is: Get good at pulling your camera model.

Here's how the setup goes: Step 1 = secure the screen model, Step 2 = secure the camera model, Step 3 = secure the string guides, Step 4 = tie the string, and Step 5 = adjust the system...

Step 1 - Secure The Screen Model - The screen model sits half on your table and half on the other team's table. Since you have only your table, you need to find a way to support the other/far side of the model. You need to rig some sort of dummy FLOOR on the other side of your north border wall. In the example below, a LEGO structure has been Dual Locked outside the table, at just the right height. Have you no extra LEGO elements? Use a wood scrap, a cardboard box, a clipboard... You can do this! Once the dummy floor is built, secure the model as shown.

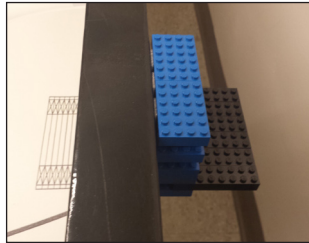

EXAMPLE DUMMY FLOOR

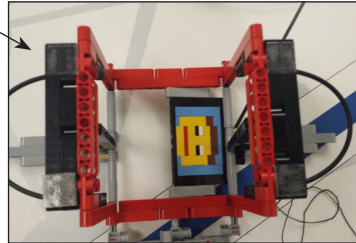

DUAL LOCK GOES HERE (4X)

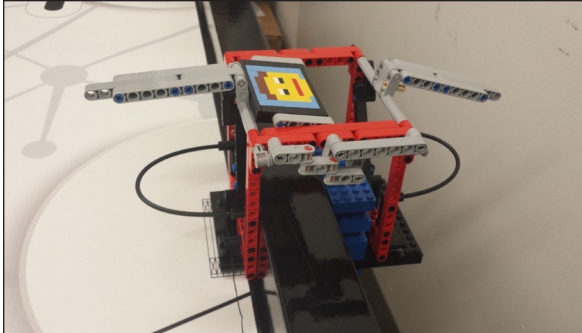

SECURED SCREEN



SECURED (AND SET) CAMERA

Step 2 - Secure The Camera - Secure as shown, with the slide all the way east.

Step 3 - Secure The String Guides - Secure to the walls, with mat lines as guides, like you did for the door...



DUAL LOCK HERE

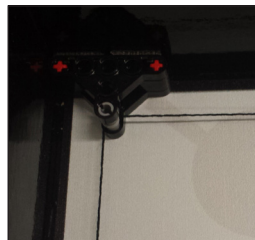

CORNER GUIDE

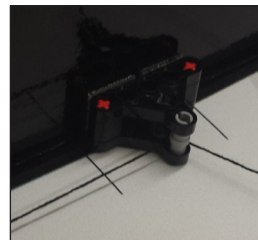

WEST CENTER GUIDE

Step 4 - Tie The String - At the camera end, tie to Position 2 (for instructions on the best way to tie the string, type “square knot” into Google Images).

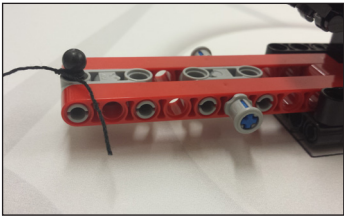

POS 1

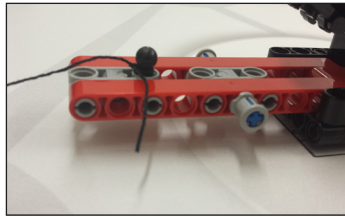

POS 2 (Good 1st try)

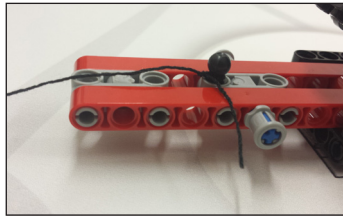

POS 3

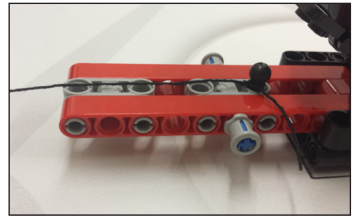

POS 4

At the screen end, route the string under the 90° connector, and tie to the ball pin in the hole between the two blue pins as shown.

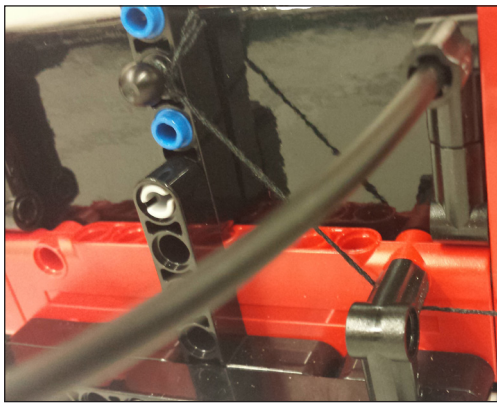

SCREEN-END STRING ROUTING

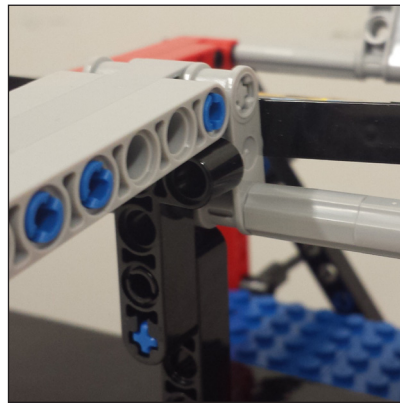

SETUP

To put the camera end in setup position, lift the gray bar, and support it with the L-Beam. Don't push the L-Beam any farther than needed for it to do its job.

Step 5 - Adjust The System - When the camera model's slider is pulled west from setup position, does the string pull the L-Beam from under the gray bar, allowing the screen to pop up??? If not, move the camera model's ball pin to other positions if needed. If your “sweet spot” can't be found by moving the camera's pin, re-tie the string as needed.

Base - Loosely place in Base: The ball, 8 penalty models, any/one loop, one set of six loose homework elements, the two minifigure people, and the blue/yellow/red robotics insert.



Field Maintenance

- **Border Walls** - Remove any obvious splinters, and cover any obvious holes.
- **Field Mat** - Make sure the mat touches the south border wall, and is centered east to west. Avoid cleaning the mat with anything that will leave a residue. Any residue, sticky or slippery, will affect the robot's performance compared to a new mat (many tournaments use new mats). Use a vacuum and/or damp cloth for dust and debris (above and below the mat). To get marks off, try a white-plastic pencil eraser. When moving the mat for transport and storage, be sure not to let it bend into a sharp kink point, which could affect the robot's movement. Tournaments using new mats should unroll the mats as far in advance of the tournament day as possible. For control of extreme curl at the east or west edges of the mat, tape is allowed, with a maximum of 1/4" (6 mm) overlap. Foam tape is not allowed. Do NOT put Dual Lock under the mat, or use it in any other than securing models as described.
- **Mission Models** - Keep the models in original condition by straightening and tightening solid connections often. Ensure that spinning axles spin freely by checking for end-to-end play and replacing any that are bent.

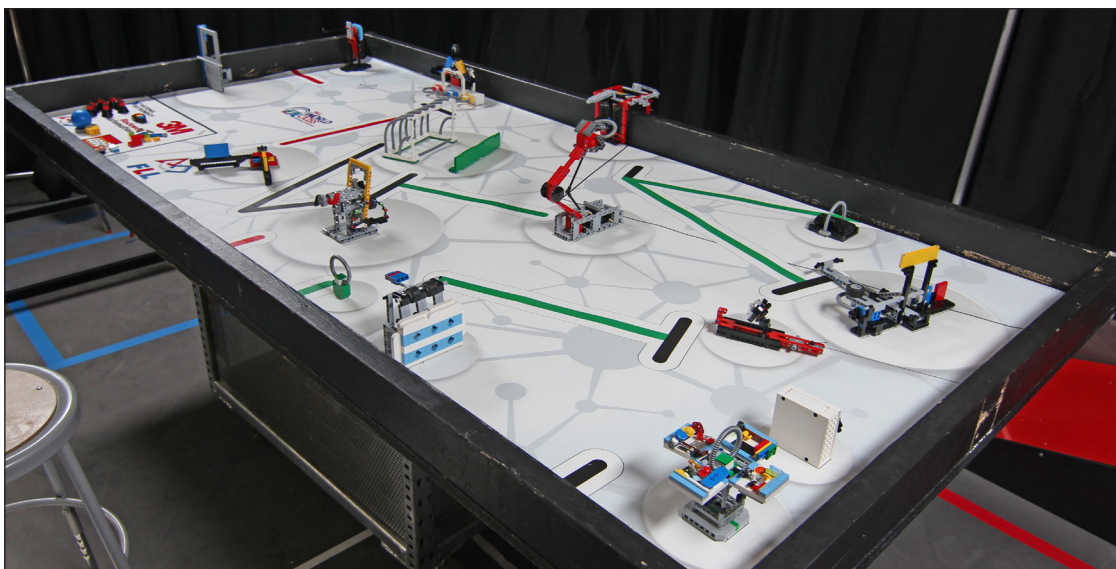
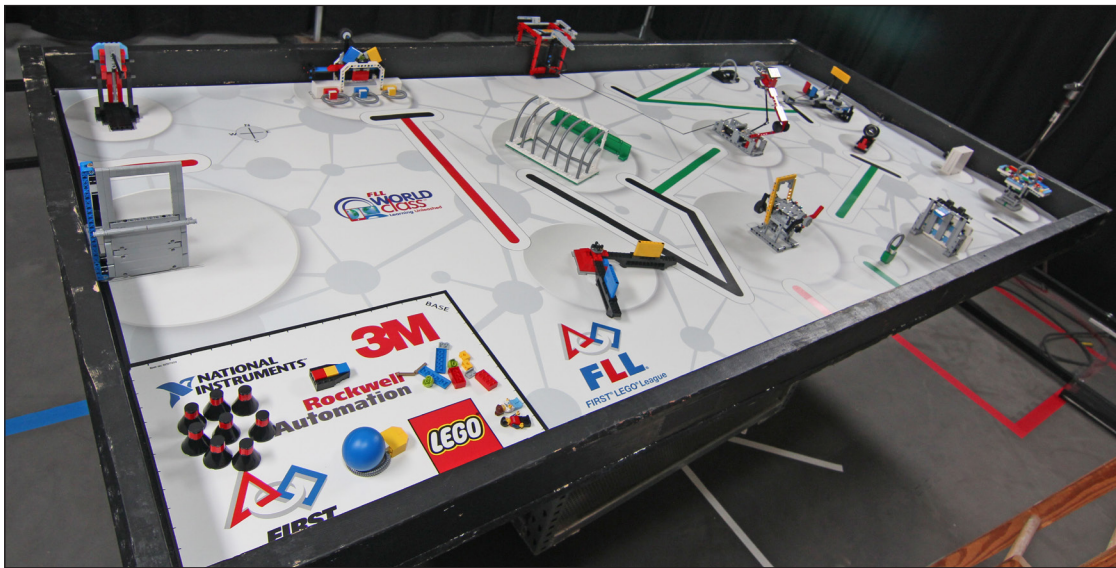



Robot Game Rules



Philosophy

1 - Gracious Professionalism® - You are “Gracious Professionals.”

- You are competing hard against PROBLEMS, while treating PEOPLE with respect and kindness - people from your own team, as well as other teams.
- You build onto other people’s ideas instead of resisting or defeating them.

2 - Interpretation - Robot game text means exactly and only what it says, so take it literally whenever possible.

- Do not interpret text based on your assumption about intent, or on how a situation might be in “real life.”
- If a detail isn’t mentioned, then it doesn’t matter.
- There are no hidden requirements or restrictions. If you’ve read everything, then you know everything.

EXAMPLES:

- *If a mission requirement is for the robot to “be on the stairs,” that doesn’t mean the robot needs to climb the steps, or go to the top!*
- *If a river is drawn on the mat but never mentioned anywhere, it’s okay for the robot to drive over it.*
- *If a mission requirement is for a cup to “be on the table,” upside down is okay.*
- *If the robot must use a robotic arm to empty the trash, this will be clearly stated. If not, any method is okay.*
- *If the robot must in fact “use a robotic arm to empty the trash,” it doesn’t matter whether the arm reaches in and grabs the trash, or instead turns the can upside down...*
- *You’re encouraged to think this way - Please learn the requirements and constraints very well, and then realize the many FREEDOMS that are left.*

3 - Benefit of the Doubt - You may get the benefit of the doubt when:

- incorrect model setup or maintenance is a factor.
- a split-second or the thickness of a (thin) line is a factor.
- a situation could “go either way” due to confusing, conflicting, or missing information.
- a referee is tempted to rule based on the “intent” of a requirement or constraint.
- no one’s really sure WHAT just happened!
- Speak up! If you (kids, not coach) disagree with the referee and can respectfully raise sufficient doubt during your post-match chat, you are given the points in question.
- This rule is not an order for the referees to be lenient, but for them to rule in your favor when they’ve done all they can to rule correctly, yet the answer is still unclear. This rule should not be part of a strategy!

4 - Variability - As you build and program, keep in mind that our suppliers, donors, and volunteers try very hard to make all fields correct and identical, but you should always expect some variability, such as:

- flaws in the border walls, including splinters, screws, holes, and tape.
- variety in lighting conditions, from hour to hour, and/or table to table.
- texture/bumps under the mat, due to imperfections, seams, or debris.
- presence or absence of tape at the east and west edges of the mat.
- waviness in the mat itself... At many tournaments, it's impossible for the mats to be rolled out in time to lose their waviness. Location and severity of waviness varies. You are being warned here. Consider this while designing.
- Two important building techniques you can use to limit the effects of variability are
 - Avoid steering systems that involve something SLIDING on the mat or border walls.
 - Cover your light sensors from surrounding light.
- Expect and design around interference where poles for lights and cameras might be mounted to walls.
- Questions about conditions at a particular tournament should be directed to that tournament's officials.

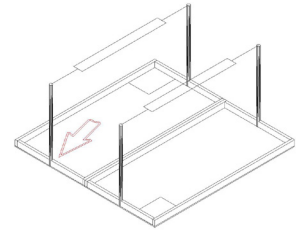

Information

5 - Precedence/Authority - You get information about the robot game from more than one place. Once in a while, there is conflict...

- So here is the order of precedence for the sources:
1 = CURRENT [Robot Game Updates](#), 2 = [Missions](#) and [Field Setup](#), 3 = [Rules](#)
- If something on a page conflicts with something else on the same page, assume the most sensible interpretation.
- If two interpretations seem equal, assume the interpretation most favorable for the team.
- On all pages, videos and pictures are for guidance and example only. Often they can not express complete information, and are therefore misleading. When there is conflict between pictures/videos and text, the text takes precedence!

6 - Robot Game Support

- The first place to go for Robot Game support is the [Robot Game Updates page](#).
<http://www.firstlegoleague.org/challenge/robotgameupdates>.
- If that doesn't help, expert support is available directly from the designer/author (Scott - Hi!) at flrobotgame@usfirst.org (usual response is 0-3 business days).
- When emailing, please state your role in FLL (member, coach, parent, mentor, referee, Partner).
- Questions organized into short simple sentences get the fastest most useful answers.
- Tournament referees are not obligated to read individual response emails.
- No new Robot Game Updates are posted after 3PM (eastern U.S.) on Fridays.
- You won't get help/advice about building or programming (that's your challenge).
- For questions about LEGO product, call (U.S.) 1-866-349-LEGO.
- Questions posted in the discussion [forum](#) (<http://forums.usfirst.org/forumdisplay.php?24-FIRST-LEGO-League>) are not seen nor responded to by Robot Game Support.
- WARNING: The forum is great for sharing ideas and getting tips from other teams, but it is not an official source of answers about anything.

7 - Coaches Meeting - If a question comes up right before the tournament, your last chance to ask it is at the “Coaches’ Meeting” (if there is one) the morning of the tournament.

- The head referee and coaches meet to identify and settle any differences BEFORE the first match...
- If you have a strategy that might confuse the referee, you should alert the referee in advance of the match if possible to avoid confusion during the actual match.
- For the rest of the day, all referee calls are final when you leave the table.

Competition Definitions

8 - Mission - A *mission* requirement is a condition the robot produces for points, sometimes in a certain way.

- You decide the order in which to try the missions, and how many to try with each software program.
- You don’t have to try every mission.
- You may re-try missions when that’s possible, but the field is not reset for that purpose.
EXAMPLE: *If a mission is for the robot to topple a stack eastward, and the robot doesn’t even reach the stack, you could try again later, since the stack is undisturbed. But if the robot topples the stack westward, since the stack doesn’t get reset, the mission is impossible to re-try.*

9 - Match - At a tournament, two robot game fields are joined back to back, and you are paired opposite another team to compete in a match. Here’s the process:

- You get to the competition table and have at least one minute to prepare (see [Rule 36](#)).
- The match starts and the timer runs for 2-1/2 minutes without stopping.
- Each match is a fresh chance for you to get your best score.
- No match has anything to do with another, and only your best score counts specifically toward the Robot Performance Award.
- “Playoffs” - if held - are just for added fun.
- If it is known in advance that you will not have another team opposite you, a volunteer or “house” team substitutes. If not, and you compete against an empty table, you get the points for any missions you tried but could not complete because the other team was missing.
- There are at least three matches, and when all teams have cycled through a match, that’s called a “round.”

Local Definitions

10 - Field - The field is every reachable place and object in the robot’s match environment.

- This includes the table top, inner border wall surfaces, field mat, and mission models.
- The field mat and the LEGO elements for building the mission models are part of your Field Setup Kit.
- The instructions for building the [mission models](#) are posted on the web.
- For full details about how to set up the Field, visit the [Field Setup](#) section... The fact that you can tell where the models go on the mat does NOT mean you know how to set up the field!

11 - Base - Base is an imaginary box formed by vertical walls that rise from the perimeter of the Base area, including the inside surface of the border walls, and by an invisible ceiling 12" (30cm) high.

- This means Base is not just an area on the mat - it's a VOLUME.
- The lines that define Base count as part of Base.
- Usually there is a gap between the mat and a side border wall... Base includes this gap (pictured in red).

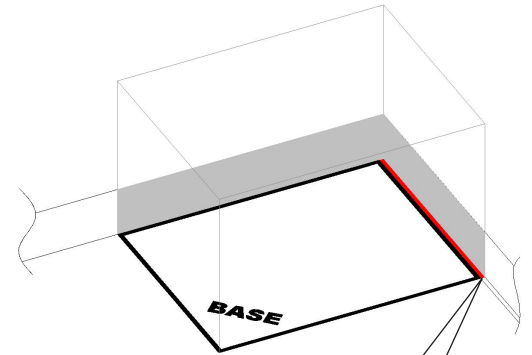

A gap between the mat and a side border wall is included in the base.

Object Definitions

12 - Robot - The robot is the LEGO MINDSTORMS® controller and anything joined with it by hand (any method, any configuration) which is designed not to separate from it except by hand.

13 - Attachments - Attachments are robot features you add or remove by hand during the match.

14 - Strategic Objects - Strategic objects are team-supplied objects, either handled by you, in Base, or handled and abandoned by the robot (wherever) by design.

15 - Mission Models - Mission models are the objects that are already on the field when you walk up to it.

16 - Cargo - Cargo is any strategic object or mission model the robot has with it for transport or release. Objects in accidental contact, objects fully released, and objects “all done being pushed” are not cargo.

Robot Allowable Equipment

17 - LEGO Elements in Original Condition - Everything you have at the field for mission-related activity (robot, attachments, and strategic objects) must be made entirely of LEGO-manufactured elements in original factory condition.

Exceptions:

- LEGO string and tubing may be cut to length.
- You may hold/reference a paper list to keep track of robot programs.
- Marker may be used only in hidden areas, for ownership identification.
- Stickers are not allowed, except LEGO stickers, applied per LEGO instructions.
- Paint, tape, glue, lubricants, zip-ties, etc. are not allowed.

18 - Regular Elements - You may use as many non-electric LEGO elements as you like, including pneumatics, rubber bands, and string, and they may be from any source or set (MINDSTORMS®/TECHNIC/DUPLO®/ BIONICLE™/STAR WARS™/HARRY POTTER™/etc.).

Exception: Factory-made wind-up/pull-back “motors” are not allowed.

Exception: You may not bring duplicate mission models to the table if they could confuse scoring.

19 - Controllers - You are allowed a maximum of one controller in the competition area in any one match. Choose one of the three LEGO-manufactured types shown here.



EV3



NXT



RCX

20 - Sensors - You are allowed as many sensors as you like, but the types are limited to touch, light, color, rotation, ultrasonic, or gyro/angle. Choose your favorite combination from among the LEGO-manufactured types shown here. No other sensors are allowed.



EV3 TOUCH

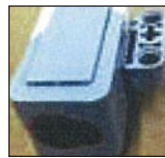

EV3 COLOR



EV3 ULTRASONIC



EV3 GYRO/ANGLE

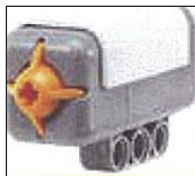

NXT TOUCH



NXT LIGHT



NXT COLOR



NXT ULTRASONIC

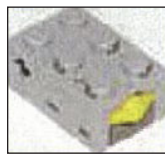

RCX TOUCH

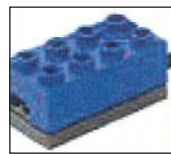

RCX LIGHT



RCX ROTATION

21 - Motors - You are allowed a maximum of four motors in any one match. Choose your favorite combination from among the LEGO-manufactured types shown here. **NO** other motors are allowed.



EV3 "LARGE"



EV3 "MEDIUM"

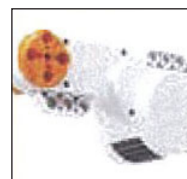

NXT



RCX

22 - Quantity Limits - The quantity limits given above don't just apply to what's on your robot "right now."

- The referee adds up everything you have with you in the competition area altogether, on and off the field.
- All of it counts toward your total for the current match.

23 - Other Electrical Elements - No other electric elements nor devices are allowed for use in any way in the competition area. Exception: LEGO wires and converter cables are allowed as needed.

- Spare electrical parts are allowed in the PIT area.
- Objects functioning as remote controls are not allowed anywhere, any time. Bluetooth must be off.

24 - Software - The robot may only be programmed using LEGO MINDSTORMS RCX, NXT, EV3, or RoboLab, software (any release). No other software is allowed.

- Patches, add-ons, and new versions of the allowable software from the manufacturers (LEGO and National Instruments) are allowed, but tool kits, including the LabVIEW tool kit, are not allowed.
- This rule puts a cap on software-related unfairness, and puts a cap on what we can reasonably ask tournament judges to become versed in - thanks for your understanding!

25 - Violation - If the robot is in violation of the allowable equipment rule and cannot be corrected, the decision about exactly what to do rests with the tournament officials, but it is possible the team may not be eligible for awards.

Status Definitions

26 - Autonomous → Offline → Autonomous → Offline → Autonomous...

- Following every time you start (or restart) the robot, it is “autonomous” and allowed to perform.
 - All strategic changes to the field outside Base must be caused by an autonomous robot (never by an offline robot, and never by your hands).
- When you next touch your autonomous robot, it is “offline” and must be restarted from Base.
 - While offline, the robot is okay to handle per [Rule 41](#) and restart per [Rules 39](#) and [40](#) when you’re ready.

27 - In - An object is “in,” “into,” or has “reached” an area if any bit of that object crosses the area’s perimeter.

- Said another way... To be “in” an area is to penetrate the volume over or below what defines that area.
- Barely “in” is considered “in” unless “COMPLETELY in” is required.
- “Touching” is not part of the requirement for being “in.”
- Objects are ruled on independent of each other, and independent of their transports/containers.
 - Exception: A cluster of small objects is considered one object.
- “Out” and “outside” always mean COMPLETELY out.

EXAMPLES OF IN AND OUT

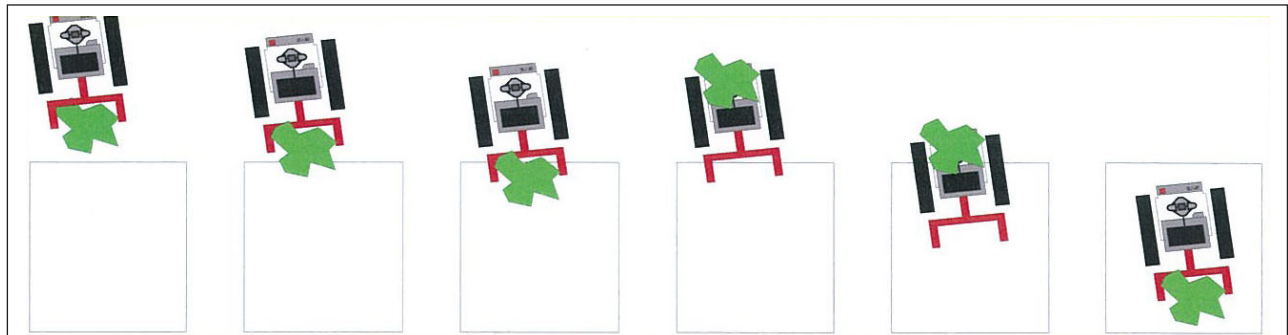

ROBOT = OUT
CARGO = OUT

ROBOT = OUT
CARGO = IN

ROBOT = IN
CARGO = IN

ROBOT = IN
CARGO = OUT

ROBOT = IN
CARGO = IN

ROBOT + CARGO
“COMPLETELY IN”

28 - Touching

- Only objects in direct contact are considered “touching.”
- Any amount of direct contact counts as touching.
- Touching is not required unless the word “touching” is used.
 - Exception: Only for the robot, an indirect touch counts as a touch.

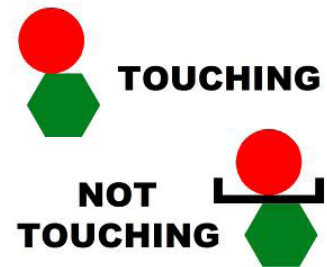

Robot Action Rules

29 - Success, Loss, Failure, and Chaos - Anything your autonomous robot does to your field outside Base (good or bad) stays that way, unless the ROBOT changes it. Exception: [Rule 50](#).

- Mission models are not fixed or reset. Stray objects are not moved out of the robot’s way.
- Cargo the robot loses contact with outside Base is left/stranded wherever it comes to rest.
So... The robot can ruin its own opportunity to accomplish tasks, and can even spoil previous results.

30 - Model Damage - Model damage is when a model outside Base is made defective and/or its Dual Lock is separated by an autonomous robot. (It can also happen when a fashion runway collapses!)

- Model damage is not repaired during the match ([Rule 29](#)). Exception: [Rule 50](#).
- If a model is put into a scoring condition, but is damaged in the process, the mission marked scoreless.
- If instead the scoring model gets damaged during an obviously unrelated action later (even just seconds later)...
- If the scoring condition is still visible, it can still score.
- If the scoring condition is no longer visible, it can not score.
- Any scoring success which obviously depended on model damage is marked scoreless.
- Any model damage obviously due to poor field setup/maintenance is scored with benefit of the doubt.

31 - Interference - Interference is when your robot disturbs the other team’s field or robot.

- Your robot may not have any effect on the other team’s robot, field, or strategy, unless it’s allowed in a mission.
- Any points you or your robot potentially cost the other team are given to them automatically.
- If two robots become entangled, they are both allowed to restart without penalty. Any cargo involved is given to the team in Base, whether or not it has ever been there before.
- As a matter of luck, the other team might out-perform you in a competitive interactive mission, or might fail to help you in a cooperative interactive mission. The effects are the same, and neither is considered interference.

32 - Junk Penalty - A junk penalty is given at the end of the match for each strategic object abandoned outside Base.

33 - Sprawl Penalty [Match End-Based] - A sprawl penalty occurs at the end of the match if either:

- the robot’s max dimension is obviously greater than twice the (south/north) width of Base.
- a strategic object extends out of Base obviously farther than the (south/north) width of Base.

The penalty’s value is given in the [Missions on page 29](#).

Team/Hand Action

34 - Robot Operators

- Only two team members at a time are allowed right next to the competition table except during repair emergencies.
- The rest of the team must stand back, as directed by tournament officials, but not too far, because different members may tag in or out as desired at any time, as long as the two-member limit is kept.

35 - Storage - You are allowed to store things in Base, outside Base, and even off the table...

- An object in storage is one that you're allowed to handle, and which counts as being in Base, even if it's not actually there. Stored objects are defined as:
 - anything team-supplied, which the robot has not moved out of Base.
 - anything in Base when the match started, which the robot has not moved out of Base.
 - anything brought to Base by the robot.
- You may at any time handle stored objects the robot is not interacting with, including the placement of objects (completely in Base) for the robot to interact with during an autonomous period.
- Stored objects are not allowed to make contact with anything outside Base except other stored objects.
- Off-field storage is usually in a box or tray on a stand.
- On-field storage and handling of the robot and other objects may extend over Base lines, as long as there is absolutely nothing strategic or disruptive about the placement. Please do try to keep all on-field storage in Base.
- Team-supplied objects held by members away from the table must be inspected before the match starts.
- Mission models and objects worth points must always stay in view of the referee.

36 - Pre-Match Preparation - This is the period after you get to the field and before the match starts.

- This is your time (at least 1 minute - it varies) to ready your equipment and compose yourself.
- At this time only, you may calibrate light & color sensors outside Base (this is an exception to [Rule 38](#)), and VISUALLY inspect the field (see [Rule 37](#)).
- At this time (and others – see [Rule 41](#)) you may also store and arrange equipment, charge pneumatics, set mechanisms, select a program, load and aim the robot, and get everything into “starting position” ([Rule 39](#)).

37 - Field Quality Control

- You may not take mission models apart, even temporarily.
- During your pre-match preparation time only, you may ask the referee to double-check that a particular setup is correct/within spec, but you may not request any custom setup, in or out of the specified range.

38 - Changes Outside Base - You may not strategically place, send, extend, use, or affect anything outside Base by hand. You may not make any changes outside Base except by:

- storing objects ([Rule 35](#)).
- removing robot fragments ([Rule 46](#)).
- a proper robot start ([Rule 40](#)).
- shutting off your robot ([Rule 47](#)).
- removing your robot ([Rules 42 and 49](#)).
- accident ([Rule 50](#)).

39 - Start/Restart Position

- For the match start and all restarts:

- EVERY BIT of the robot, including its installed attachments & wires, and everything touching it, and any objects it is about to move or use, must ALL fit COMPLETELY in Base.
- The ROBOT may be touching objects it is about to move or use, but your HANDS may not.
- The robot's program may or may not already be running, but everything must be motionless.
- If the robot is about to move a mission model from Base, you must be able to pick that model up and have NOTHING come with it (only do this if asked).
- You may design/use a LEGO frame/"jig" to aim the robot, but its use must be completely in Base at all times, and you must let go of it prior to starting/restarting. You may not mark the mat nor use paper for aiming. (Reference [Rules 14](#), [17](#), and [40](#).)

EVERYTHING MUST START COMPLETELY IN BASE

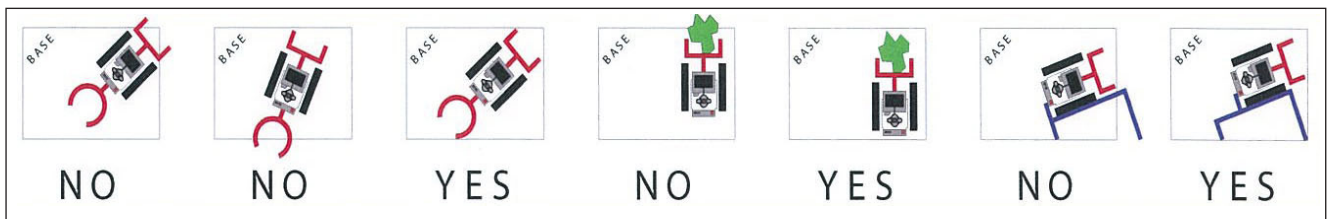

40 - Starting Procedure

- For the match start, the referee checks for proper starting position, then signals your readiness to the announcer.
- As the countdown starts, you reach in with one hand, ready to either touch a button or signal a sensor to prompt the robot's program.
- During the countdown: Except for the button/signal prompt, you may not handle the robot or anything it's touching or about to move or use.
- The exact time to start is at the beginning of the last word in the countdown, such as "Ready, set, GO!"
- If a non-word signal is used, like a beep or buzzer, the start is at the beginning of that signal.
- At the exact starting time, you either touch a button or signal a sensor to start or prompt the robot's program. The robot is now considered to be started and autonomous.
- For all other starts (called restarts), there's no countdown. The referee watches to be sure things are in proper starting position, and you activate the robot whenever you like.
- If the robot enters and leaves Base with no interruption or influence from you, this is not considered a restart, so starting position and procedure rules don't apply.
- Once started, the robot may go anywhere or extend to any size, in any direction, including over borders.

41 - Mid-Match Offline Robot - When the robot's offline, in Base... In addition to the important actions allowed in the third part of [Rule 36](#), you may unload, repair, and re-configure it.

42 - Forced Restart - Any time you touch the robot, no matter where it is, it is "offline" and must immediately be picked up and carried to Base (if it's not already there), where Rule 41 applies. When you're ready, follow [Rules 39](#) and [40](#) to make it autonomous again.



43 - Robot Penalty - These occur whenever you touch an autonomous robot which is OUTSIDE BASE. The penalty's value is given in the Missions, below.

44 - Cargo Penalty - Any time you touch the robot, no matter where it is, if it has cargo OUTSIDE BASE it didn't have during the most recent start, the referee takes that cargo out of play.

45 - Sprawl Penalty [Hand-Based] - A sprawl penalty occurs whenever you either:

- touch the robot while its max dimension is obviously greater than twice the (south/north) width of Base.
- touch a strategic object while it extends out of Base farther than the (south/north) width of Base.

The penalty's value is given in the Missions, below.

46 - Broken Robot - You may pick up fragments of an obviously broken robot any time, anywhere with no penalty.

47 - Motor Strain - If you won't be trying any more missions, and your robot is outside Base, straining its motors, and no longer traveling, you may non-strategically shut it off and leave it in place with no penalty.

48 - Strategic/Precision Stop

- If your eyes are doing the work of a sensor...
- If your window of execution for touching/interrupting the autonomous robot is conveniently precise... (3, 2, 1, GRAB NOW!)...
- If a new scoring condition is produced or preserved by the precision of the grab... and these things are obvious to the referee, missions benefitting are marked scoreless.

EXAMPLE: If the robot needs to push a lever somewhere between Position 3 and Position 4, and you touch your "healthy" robot while the lever is STILL MOVING between those positions... No score.

49 - Chain Reactions - If the (hand) movement of the offline robot will unavoidably cause/allow the movement of any non-cargo object outside Base, such as something being "held up" or "held back," the movement of that restrained object (the chain reaction) must be kept to an absolute minimum.

- Allow the stored energy to dissipate slowly, over as little distance as possible.
- Missions obviously benefitting from hand-help are marked scoreless.

50 - Reversible Changes - When things such as a sleeve, table-bump, renegade offline robot, or illegal action disturb the field in a non-trivial way, the referee physically reverses the change if he or she feels that's easy. In cases where the change is too hard to undo...

- If the accident was the team's fault, negative scoring effects stand, and positive scoring effects do not.
- If the accident was not the team's fault, the team gets benefit of the doubt on all dependent scoring.

End of Match/Scoring

51 - The Scoring Process

- END-OF-MATCH SCORING - Most of your score depends on the conditions at the exact time the match ends.
- The field is the evidence of most of your score... When the match ends, PLEASE DON'T TOUCH ANYTHING! The referee first needs time to record the condition of the field on a score sheet and come to agreement with you (kids only) about what points were scored or missed and why.
- Points aren't given for results the robot produces during the match but then trashes before the end.
- Points are not given nor taken away for results produced after the match end signal ends.
- If you agree with the score, you sign the sheet, and the score is final.
- If you don't agree, tell the referee nicely. Referees can be wrong, and when they are, they want to know.
- After a short discussion, if the referee is not sure about the score, the head referee makes the final decision.
- MID-MATCH SCORING - Sometimes part of your score is permanently determined during the match instead of at the end.

EXAMPLE: *When a mission is required to be achieved through a specific method, but is achieved by some other method, it is marked scoreless. Please don't try to show video to the referees.*

EXAMPLE: *If the robot puts Model A into a scoring condition by destroying Model B, the Model A mission is marked scoreless.*

EXAMPLE: *If the robot is required to drive over something in the middle of the match, the referee will mark the score for that when it happens, since no lingering evidence will be visible.*

- TIE BREAKING - Ties are broken using 2nd, then 3rd highest scores. In the rare occasion of a tie across all three matches, tournament officials decide what to do. Options include simply awarding multiple same-place awards.
- ACCIDENTAL REMOVAL - Please don't walk away with mission models from the competition field, and bring them back quickly if you do. Thanks.



Changes for 2014

Trivial

- Word-count has been reduced by ~12%.
- Rules are categorized now.
 - By similarity first, then by chronology.
 - Rules that govern are separated from definitions.
 - Rules governing the robot are separated from rules governing the team.
- Giant rules and branching/logic rules have been broken down for easier reading.
- Many rules have been clarified, refreshed, streamlined, and tightened for readability and simplicity.
- Cross-references have been added for concept reinforcement.

Significant

- A loophole has been removed: Picking up a huge strategic object left only partly in Base by the robot will now cause a sprawl penalty. See [Rules 33](#) and [45](#).
- A cluster of small objects is considered one object when evaluating “in.” See [Rule 27](#).
- The gravity test has been lightened up and folded into “Starting/Restart Position.” See [Rule 39](#).

Critical Warning

While it's obvious that everyone needs to become an expert on the details of the Missions below, it's also EXTREMELY IMPORTANT for everyone, veteran teams as well as rookies, to read the OTHER THREE CRITICAL ROBOT GAME PAGES: [Field Setup](#) + [Rules](#) + [Updates](#), and go back to them repeatedly. Look at the benefits.

TEAMS WHO HAVE READ EVERYTHING

- have fewer questions
- have less rework
- have fewer surprises at tournaments
- score higher
- have more fun

TEAMS WHO DON'T

- operate in a fog
- start over and lose time
- learn a lot from... referees
- lose points
- get stressed





Robot Game Missions

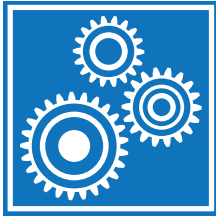

Opening Doors

Required condition visible at the end of the match:

- The door must be open enough for the referee to notice.

Required methods, constraints:

- The handle was pushed down.

Value: 15

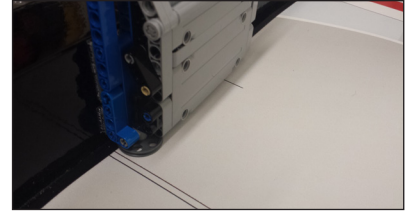

Cloud Access

Required condition visible at the end of the match:

- The SD card is up.

Required methods, constraints:

- The correct “key” was inserted in the cloud.

Value: 30

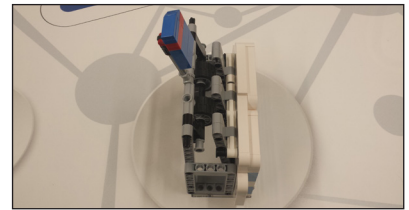

Community Learning

Required condition visible at the end of the match:

- The knowledge & skill (loop) is no longer touching the community model.

Required methods, constraints:

- None.

Value: 25

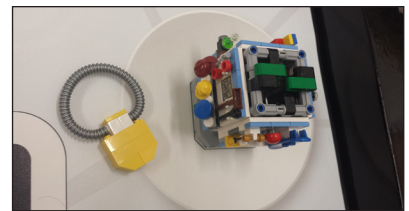

Robotics Competition

Required condition visible at the end of the match:

- The robotics insert is installed in the place shown.
- The loop is no longer touching the robotic arm model.

Required methods, constraints:

- No team supplied object is touching the robotics insert.
- The loop was released due to movement of the slider only.

Value/Insert: 25

Value/Insert + Loop: 55

(Possible Scores = 25 or 55)

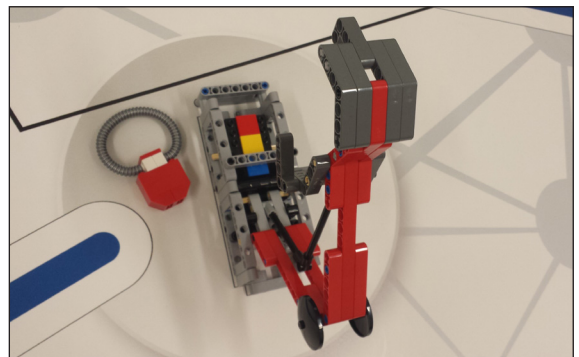

Using the Right Senses

Required condition visible at the end of the match:

- The loop is no longer touching the senses model.

Required methods, constraints:

- The loop was released due to movement of the slider only.

Value: 40

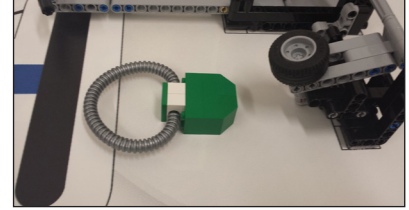

Thinking Outside the Box

Required condition visible at the end of the match:

- The idea model is no longer touching the box model.
- If the idea is no longer touching the model, the bulb faces up.

Required methods, constraints:

- The box model was never in Base.

Value/Idea Out, Bulb Down: 25

Value/Idea Out, Bulb Up: 40

(Possible Scores = 25 or 40)

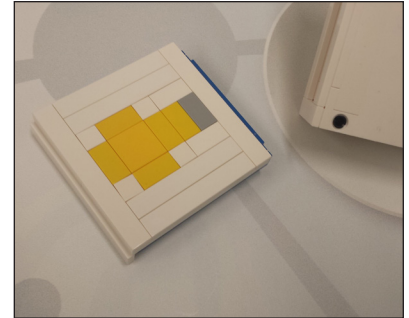

Remote Communications/Learning

Required condition visible at the end of the match:

- None.

Required methods, constraints:

- The referee has seen the robot pull the slider west.

Value: 40

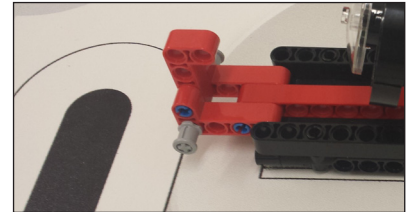

Search Engine

Required condition visible at the end of the match:

- The color wheel has spun at least once.
- If a single color appears in the white frame, its matching loop is no longer touching the model.
- If two colors appear in the white frame, the remaining color's loop is no longer touching the model.
- Both "not desired" loops must be touching the model, in their holes.

Required methods, constraints:

- Nothing has caused the color wheel to spin except the slider being pushed.

Value/Slider: 15

Value/Slider + Loop: 60

(Possible Scores = 15 or 60)

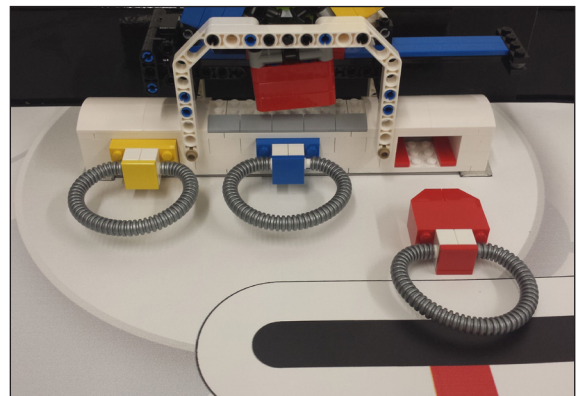

Sports

Required condition visible at the end of the match:

- The ball is touching the mat in the net.

Required methods, constraints:

- All equipment involved with the shot was completely east/north of the “Shot Lines” while sending the ball to the net.

Value/“Took A Shot”: 30

Value/Shot + Goal: 60

(Possible Scores = 30 or 60)

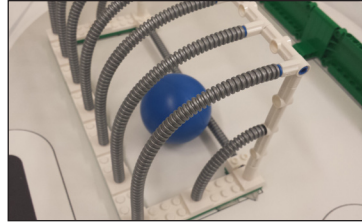

GOAL



SHOT LINES

Reverse Engineering

Required condition visible at the end of the match:

- Your basket is in Base.
- You have built a model “identical” to the one the other team put in your basket. Connections need to be the same, but where rotation is a factor, “close” is okay.
- The model is in base.

Required methods, constraints:

- None.

Value/Basket: 30

Value/Basket + Model: 45

(Possible Scores = 30 or 45)

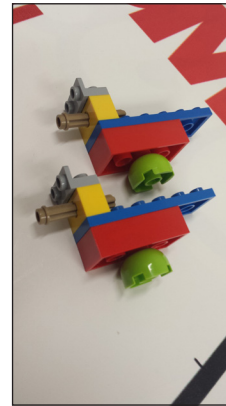

EXAMPLE

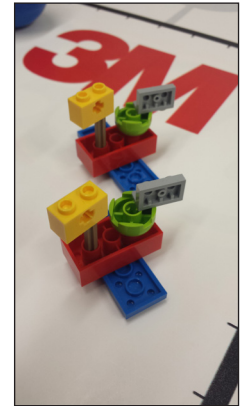

EXAMPLE

Adapting to Changing Conditions

Required condition visible at the end of the match:

- The model is rotated 90° counter-clockwise from its setup position as shown here.

Required methods, constraints:

- None.

Value: 15

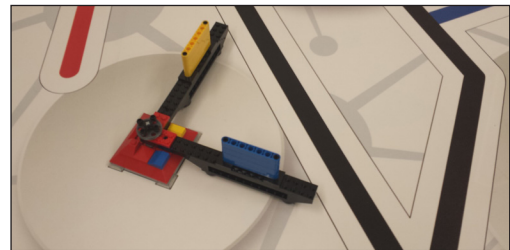

Apprenticeship

Required condition visible at the end of the match:

- The people are both bound (any way you like) to a model you design/supply, which represents a skill, achievement, career, or hobby that has meaning for your team.
- The model is touching the white circle around the scale.
- The model is not in Base.
- Binding mission models is usually not allowed under [Rule 39](#), but we make an exception here.
- The model can be simple or complex, primitive or realistic – it’s up to you.

Required methods, constraints:

- None.

Value/Model: 20

Value/Model Touching Circle: 35

(Possible Scores = 20 or 35)



Engagement

Required condition visible at the end of the match:

- Yellow section is moved south.
- Dial is obviously clockwise of its setup position; see chart for score.

Required methods, constraints

- The dial may only move as a result of the robot turning the pinwheel.
- Between any two starts/restarts (see [Rules 39 & 40](#)), the pinwheel may be turned 180° maximum.

The referee will undo any extras turns.

Value/Engage: 20

Value/90° Pinwheel Turns: See Chart For Percentage Added To Your Non-Engagement Mission Score Total

EXAMPLE: If your score from all other missions is 350, and the robot does one 90° turn, that's worth 35.

EXAMPLE: If your score from all other missions is 300, and the robot does six 90° turns, that's worth 45.

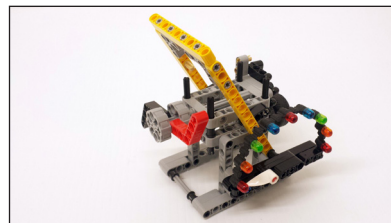

ENGAGED

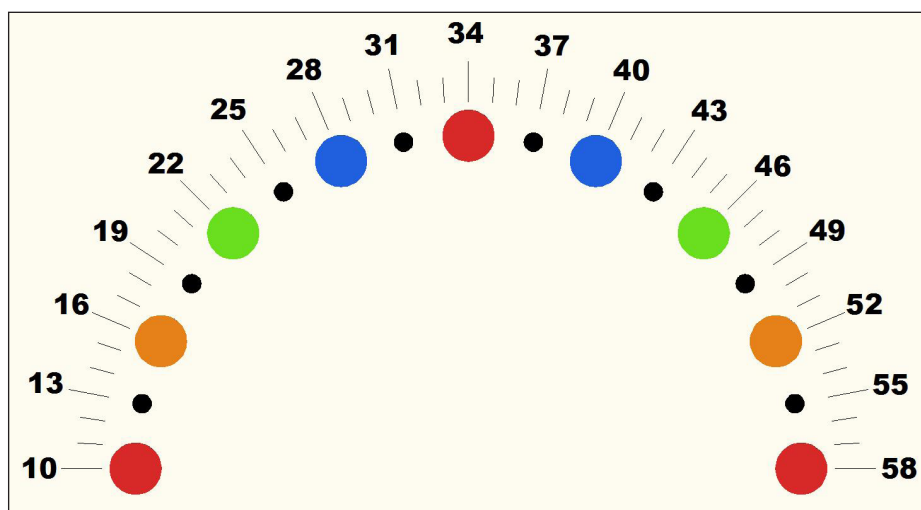

PERCENTAGE ADDED TO NON-ENGAGEMENT TOTAL

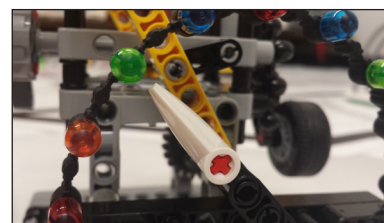

EXAMPLE: 22%



EXAMPLE: 25%

Project-Based Learning

Required condition visible at the end of the match:

- The scale holds loops (representing knowledge and skill) as shown.

Required methods, constraints:

- None.

Value/1st Loop: 20

Value/More Loops: 10 EACH

(Possible Scores = 0 or 20 or 30 or 40 or 50 or 60 or 70 or 80 or 90)

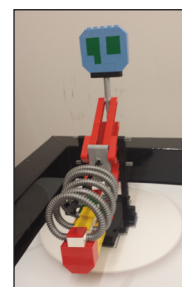

Penalties

If a Robot, Sprawl, or Junk penalty earned (as described in the Rules), the referee keeps account by obvious placement of these penalty markers in some manner as to stay out of the way of you and your robot. Loss of cargo is its own penalty.

Robot, Sprawl, or Junk Penalty: -10 EACH

(Max Penalties Of These Types = -80)

Cargo Penalty: Loss Of Cargo





www.usfirst.org | www.firstlegoleague.org | FLL is the result of an exciting alliance between *FIRST*[®] and the LEGO Group.

©2014 The United States Foundation for Inspiration and Recognition of Science and Technology (*FIRST*[®]) and the LEGO Group. All rights reserved. Official *FIRST*[®] LEGO[®] League Teams and FLL[®] Operational Partners are permitted to make reproductions for team and Partner use only. Any use, reproduction, or duplication for purposes other than official FLL use or directly by the FLL team as part of its FLL participation is strictly prohibited without specific written permission from *FIRST* and the LEGO Group.

FIRST[®] and Gracious Professionalism[®] are registered trademarks of *FIRST*. LEGO[®] and MINDSTORMS[®] are registered trademarks of the LEGO Group. *FIRST*[®] LEGO[®] League, FLL[®], and FLL WORLD CLASS[™] are jointly held trademarks of *FIRST* and the LEGO Group. All other trademarks are the property of their respective owners.